

Operator's Manual

for

Aimpoint CompM2 and ML2

CHAPTER I

1.1. Presentation

Aimpoint's Reflex Sights are rugged precision electronic optical red dot sights developed for civilian, military and law enforcement applications.

Aimpoint sights are designed for the "two eyes open" method of sighting, which greatly enhances situational awareness and target acquisition speed. Thanks to the parallax-free design, the dot follows the movement of the user's eye while remaining fixed on the target, eliminating any need for centering. Further, the sight allows for unlimited eye-relief.

The CompM2 is compatible with 1st, 2nd and 3rd generation night vision devices, while the CompML2 is optimized for applications, which do not require night vision compatibility. Aimpoint has now introduced the **CET** technology, a radical advancement in red dot sighting performance with over 30 times longer battery life than the existing XD - sights.

1.2 Specification

Model CompM2, CompML2, CompM2-2X and CompML2-2X

Material - housing:	Extruded, high strength aluminum, anodized
Surface finish:	Hard Anodized, Graphite Gray, matte
Material – lens covers:	Thermoplastic elastomer, black, non-glare
Optical magnification:	1X for all models except for 2X
Eye relief:	Unlimited, no centering required
Optical coating:	Anti Reflex coating, all surfaces Multi-layer coating for reflection Band Pass coating for NVD compatibility (CompM2)
Dot size:	4 MOA except for 2X, which has 2 MOA dot size
Switch, dot brightness:	CompM2 / M2-2X: 10 positions: 4 NVD, 6 daylight of which 1 Extra Bright CompML2 / ML2-2X: 10 positions: 1 Off, 9 daylight of which 1 Extra Bright
Battery:	One 3 Volt Lithium battery type 2L76 or DL1/3N
Battery life* (hours):	1000 – 10.000 h (typically 10 years at CompM2 NVD position)

Length (incl. lens covers):	CompM2 / ML2: 130 mm (5.1") CompM2-2X / ML2-2X: 165 mm (6.5")
Width / height	CompM2 / ML2: 55 mm (2.2") CompM2-2X / ML2-2X: 60 mm (2.4")
Weight (incl. lens covers):	CompM2 / ML2: 200 gram (7.1 oz) CompM2-2X / ML2-2X: 290 gram (10.2 oz)
Adjustment:	Range $\pm 2,5$ m at 100 meters, in windage and elevation 1 click = 10 mm at 80 meters = 13 mm at 100 meters = = $\frac{1}{2}$ " at 100 yards.
Mounting:	One wide ring, 30 mm diam, or Aimpoint QR Ring
Max temperature range:	-45° C to +70° C (-50° F to 160° F)
Water resistance:	Submersible to 25 m (80 ft) water depth**

* Average values, depending on brightness setting

**Tests performed have shown that sights will stand over 100 meters (330 ft) of water depth.

MOA: Minute Of Angle 1MOA = 30 mm at 100 meters = 1" at 100 yards

NVD: Night Vision Device

1.3 Location and description of major components and functions

See fig. 1

1. Battery Lid
2. Battery (DL1/3N or similar)
3. Cover for adjustment screw

4. Adjustment Screw (windage/elevation)
5. Rotary Switch
6. Rubber Strap

7. Eye Protection
8. Lens Cover, rear
9. Lens Cover, front
10. Lens Cover for 2X Booster

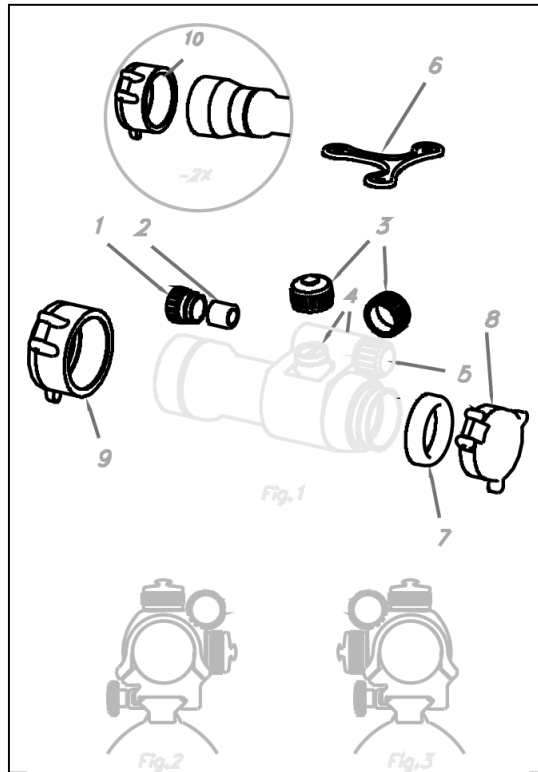

CHAPTER II

OPERATION UNDER NORMAL CONDITIONS

2.1. ASSEMBLY AND PREPARATION FOR USE

WARNING: Insure the weapon is unloaded and the safety selector is in the "safe" position before attempting to install, remove or perform maintenance on the sight.

2.1.1. Installing Battery

- a) Remove battery cap by turning it counterclockwise.
- b) Insert battery with positive (+) end toward cap.

Caution while replacing battery (not necessary when the sight is unused)

Before installing battery cap, inspect that the O-ring is present and not damaged. Failure to do so could result in water leakage into the battery compartment.

- c) Install battery cap by turning clockwise until snug. Hand tighten only. Using tools could damage equipment.
- d) Verify that red dot is present by turning the rotary switch clockwise.

2.1.2. Installing Ring and Sight on the weapon

Aimpoint's sights are designed for installation on most types of weapons. If your weapon does not have or support an appropriate base(s), please consult your dealer, gunsmith or other qualified source.

- a) Assemble the sight to the weapon by using Aimpoint's wide 30 mm ring or QR-mount. If other standard 30 mm rings are used, make sure that the ring(s) covers a length of minimum 25 mm or 1" (two standard rings could possibly be used).
- b) Ensure that the sight is correctly positioned for right or left hand shooting, see fig 2 and 3.
- c) When using lens covers, ensure that they are correctly positioned and can be opened.
Note: make sure that you have space between the bottom front part of the sight and the top of the base/weapon.
- d) Finally, make sure that all screws are firmly tightened around the sight.
- e) Complete the zeroing (2.2.1).

2.2. OPERATING PROCEDURES

2.2.1. Zeroing

Aimpoint's sights are delivered in a centered position. Normally this means that only small adjustments are necessary, providing that the base(s) are properly aligned.

CAUTION: Do not continue to adjust windage and elevation mechanisms if you encounter resistance.

The elevation adjustment screw is located on top of the sight, while the windage screw is located on the right or left side, depending on how the sight has been mounted on the weapon. (Aimpoint sights can be installed to support either right hand (fig 2) or left hand (fig 3) shooters.)

- a) Open front and rear lens covers.
- b) Turn the rotary switch clockwise until the red dot has a sufficient intensity to contrast against the target.
- c) Remove the windage and elevation adjustment caps.

NOTE: Each click of the adjustment screw corresponds to a 10 mm movement of the point of impact at 80 meters, (3 mm at 25 meters, 13 mm at 100 meters and 25 mm at 200 meters or $\frac{1}{2}$ " at 50 yds, $\frac{1}{2}$ " at 100 yds and 1" at 200 yds).

- d) Insert adjustment tool (coin, screwdriver, knife) or cartridge casing in adjustment screw slot and turn as follows:
 - To move the point of impact to the right, turn windage adjustment screw counterclockwise (clockwise if screw located on left side).
 - To move the point of impact to the left, turn windage adjustment screw clockwise (counterclockwise if screw located on left side).
 - To move the point of impact up, turn elevation adjustment screw counterclockwise.
 - To move the point of impact down, turn elevation adjustment screw clockwise.
- e) Confirm zeroing by firing at least three shots at a zeroing target. Check impact points on zeroing target to confirm accuracy and repeat above procedure if required.
- f) After initial firing, ensure that the mount and sight are secure.
- g) Turn rotary switch to OFF position (counterclockwise).
- h) Close front and rear lens covers.

CHAPTER III

OPERATION UNDER EXTREME CONDITIONS

- a) **Extreme heat** (moist or dry). No special procedures required.
- b) **Extreme cold**. Extreme cold might shorten battery life. Keep spare batteries in your inner pockets to keep them warm.
- c) **Salt air**. No special procedures required.
- d) **Sea spray, water, mud and snow**. Ensure that battery cap and two adjustment screw caps are tight before exposing the sight to sea spray, mud, snow or before immersing the sight in water. Hand tighten only.
Keep lens covers closed when sight is not being used. Clean lenses with lens paper/cloth and wipe the sight dry as soon as possible after exposure to water, sea spray, mud or snow.
- e) **Dust storms and sand storms**. Keep lens caps closed when sight is not being used.
- f) **High altitudes**. No special procedures required.

CAUTION: The lenses shall never be cleaned with fingers but with lens paper/cloth.

If no lens paper/cloth available :

- To clear away debris (sand, grass etc): blow away the dirt.
- To clean lenses: mist up the lenses and dry them with a clean and soft piece of cloth.

CHAPTER IV**TROUBLE SHOOTING PROCEDURES****4.1 RED DOT DOES NOT APPEAR**

Discharged battery	Replace battery
Battery installed incorrectly	Remove and reinstall battery with (+) toward cap
Battery is not making good contact	Clean contact surfaces and reinstall battery.
Defective rotary switch	Notify dealer/armourer

4.2 IMPOSSIBLE TO ZERO

Adjustment screw is at its limit	Check alignment of mount to barrel
Impact point is moving	Check mount stability

CHAPTER V**MAINTENANCE**

- a) This reflex sight does not require any particular maintenance while used under normal conditions.
- b) Under severe weather conditions please refer to chapter III.
- c) Keep lens covers closed whenever the sight is not in use.
- d) Warehouse storage: Remove battery and allow lens surfaces to dry completely (if wet) before closing the lens covers.
- e) To clean lenses refer to NOTE in chapter III.

Aimpoint AB**Aimpoint Inc.****www.aimpoint.com**